

# PLD Target Manipulator



*PVD Products provides custom engineering for UHV PLD target manipulators to fit your deposition chamber. These manipulators are based on a single, co-axial, magnetically coupled rotary feedthrough. Target assemblies incorporate silicon nitride bearings and provide extended life even at high rotational speeds or high substrate temperatures. Hollow shafts on the target assemblies reduce heat transfer to the gears and bearings and provide for longer operating times. The feedthrough does not use any rotary-bellows seals, which might fail during continuous use. This manipulator requires only one penetration through the mother-flange, to provide more flexibility in properly locating the target assembly within your PLD chamber.*



**Horizontally oriented, 3-position, 50-mm  $\phi$  target assembly with top water-cooled shield removed mounted on 10" CF mother-flange.**

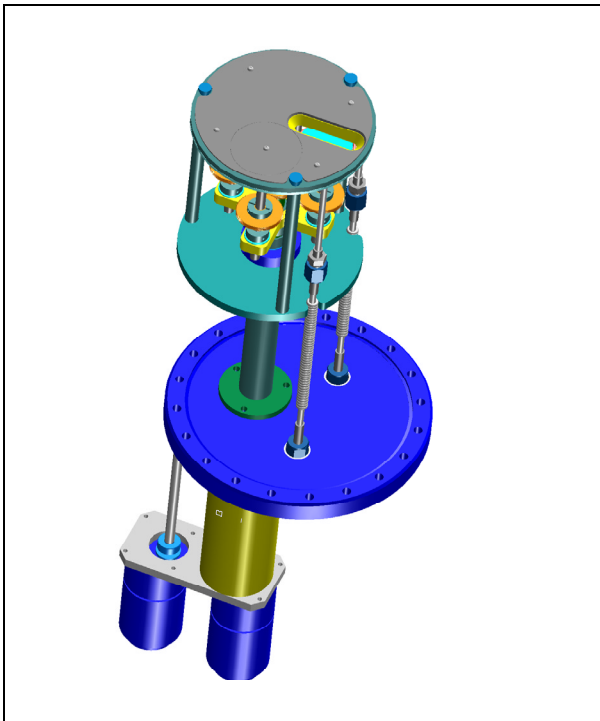

**Solid model of a Target Manipulator holding four 2-inch diameter targets with optional water-cooled shield and computer driven stepper motor to index (change) the active target.**

*An AC motor with a 19" rack-mounted or hand-held electronic motor drive unit provides continuous target rotation with speeds from 5 to 35 RPM. Water-cooled shields are available to protect both the active and inactive targets from vapor back-scattered by background gas, as well as thermal radiation from substrate heaters. Target assemblies are designed to provide easy target replacement.*

*Manual target indexing with détentes is provided to indicate proper target position, or an optional computer-controlled stepper motor system is available.*

## **PLD Target Manipulator Features**

- *Multiple configurations - all UHV compatible*
- *Co-axial, magnetically-coupled rotary feedthrough*
- *Design provides for easy target changes*
- *Water-cooled target shielding for high temperature applications*
- *Manual or optional automated target indexing with LabVIEW™ software control*

### Custom Target Manipulator Configurations:

Custom configurations are available on request for target diameters ranging from 6 to 300 mm. Target thickness up to 12 mm can be accommodated. Assemblies can be mounted on flanges ranging in size from 2.75" (70-mm) to 16.5" (420-mm). To obtain a quote for your specific needs, please refer to the adjacent figure and provide us with the following information:

- Number, diameter, and thickness of targets ( $N, d, t$ )
- Orientation of targets within the deposition chamber  
-Horizontal or Vertical ( $H, V$ ), or at specified angle ( $\theta$ )
- Mother flange Diameter ( $D_2$ )
- Distance from vacuum surface to target surface ( $L$ )
- Distances from the center of the mother flange to the center of the active target ( $L_V, L_H$ )
- Slot length and width ( $l, w$ )
- Slot orientation
- Laser beam position.

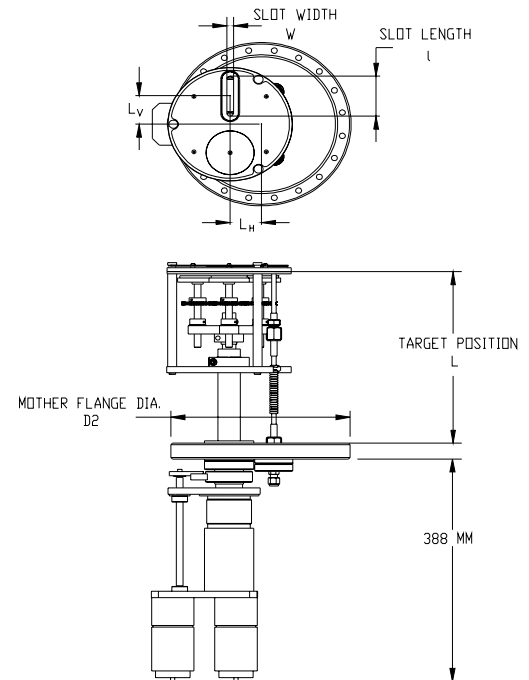

The customer is responsible for providing PVD Products with any information regarding space restrictions within the customer's chamber. Once a manipulator has been completely specified, PVD Products will provide the customer with a computer-aided 3-D solid model for the customer to approve prior to fabrication.

### Standard Specifications:

Target rotational speeds:	Variable from 5 to 35 RPM
Electrical requirements:	100-120 VAC, 50/60Hz, 4A
SCU-1000 Electronic drive unit:	19" rack mount x 3.5" high x 18" deep
Max. bake-out temperature:	200 °C with magnet assembly removed
Requirements for optional water-cooled stage:	0.5 GPM, 75 PSI max, filtered, 27 °C 1/4" Swagelock™ fittings

### Options:

Water-cooled target shield with slot for laser and plume.

Z-axis target motion: Adds 50-mm (or larger) stroke to the target assembly from the base of the mother flange within the deposition chamber using a bellows-sealed stage. The overall length external to the chamber is increased by 4.5". A motor drive unit for the stage is available at additional cost.

Internal Z-axis target height adjustment: Allows up to 25 mm of target height and water-cooled shield adjustment (adjustment made internal to chamber, or with manipulator assembly on the bench).

Computer-controlled motor drive for target indexing and excimer laser functions.

Shutter assemblies.

Support shafts for vertical target mounting configurations.

User specified accessory ports on main flange for shutters, bias rings, etc.

Higher target rotational speed.