

## Features

- ▶ High speed, direct drive
- ▶ Stackable for multi-axis motion
- ▶ 30, 65, and 100  $\mu\text{m}$  ranges of motion
- ▶ **pico**™ sensor technology
- ▶ Closed loop control

## Typical Applications

- ▶ Interferometry
- ▶ Nanomanipulation
- ▶ High speed lens focusing
- ▶ Fiber optics

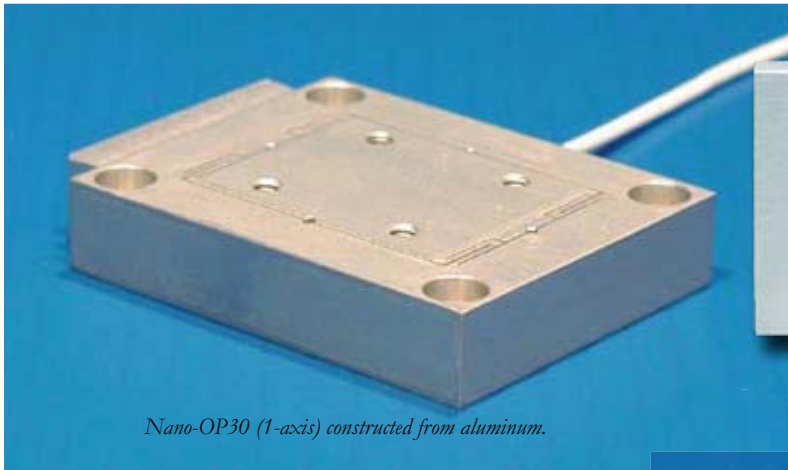

Nano-OP30 (1-axis) constructed from aluminum.



Nano-OP65 (1-axis) constructed from aluminum.

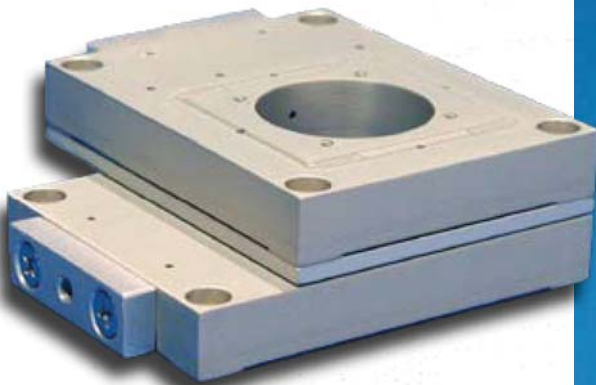

Custom stacked Nano-OP30 with 1.25" diameter aperture.

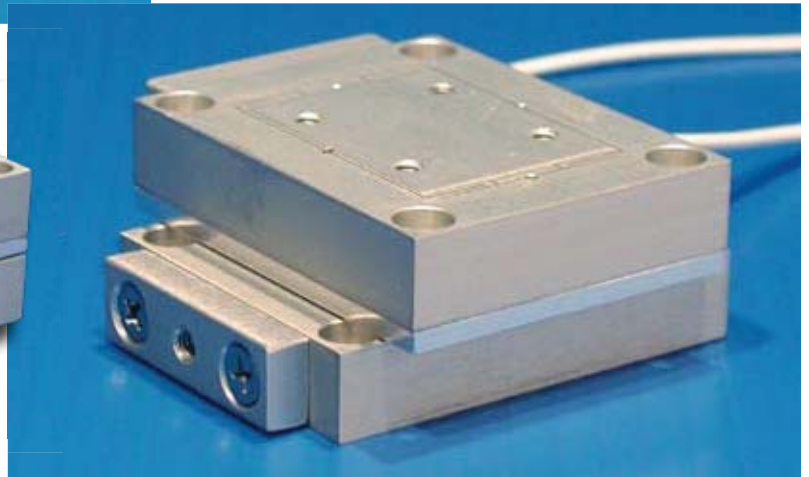

Stacked Nano-OP30's (2-axis) constructed from aluminum.

## Product Description

The Nano-OP Series is a versatile group of compact nanopositioners which can be configured to fit into a wide variety of applications. Individual, single axis stages may be combined to form multi-axis systems. The Nano-OP Series are available with 30, 65, and 100 micron ranges of motion. They can be constructed from aluminum, invar, or titanium and can be customized to suit unique requirements. Internal position sensors utilizing proprietary **pico**™ technology provide absolute, repeatable position measurement with picometer accuracy under closed loop control.

פז"מ-טק (1991) בע"מ

מייקל סטורץ | 02.583.2511

PaZaM-tech@pobox.com

www.PaZaM-tech.co.il

## Technical Specifications

Range of motion (Nano-OP30) .....	30 $\mu\text{m}$	$\theta_{\text{roll}}, \theta_{\text{pitch}}$ (typical) .....	$\leq 1 \mu\text{rad}$
Range of motion (Nano-OP65) .....	65 $\mu\text{m}$	$\theta_{\text{yaw}}$ (typical) .....	$\leq 2 \mu\text{rad}$
Range of motion (Nano-OP100) .....	100 $\mu\text{m}$	Recommended max. load (horizontal)* .....	1.0 kg
Resolution (30/65/100 $\mu\text{m}$ ) .....	0.06/0.13/0.2 nm	Recommended max. load (vertical)* .....	0.5 kg
Resonant Frequency .....	4 kHz $\pm 20\%$	Body Material .....	Al, Invar or Titanium
Resonant Frequency (100g load) .....	2 kHz $\pm 20\%$	Controller .....	Nano-Drive™
Stiffness .....	3.0 N/ $\mu\text{m}$ $\pm 20\%$	* Larger load requirements should be discussed with our engineering staff.	

### Low Position Noise

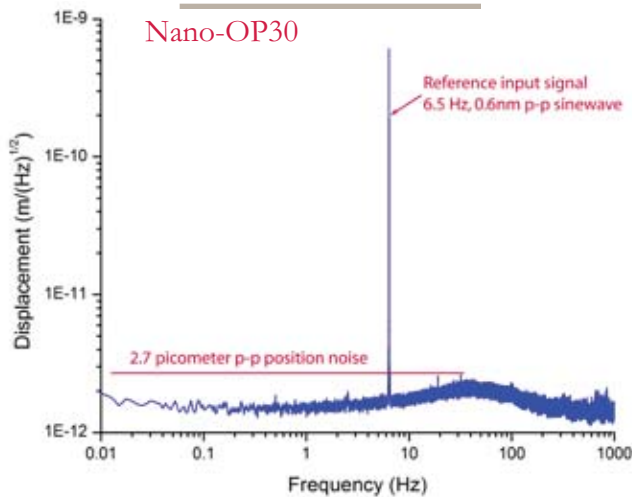

### Nano-OP High Speed Lens Positioners

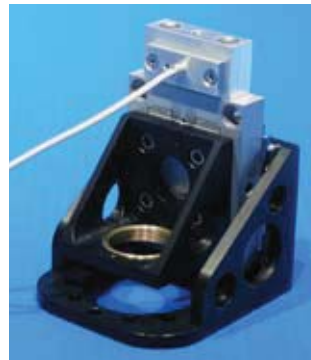

High speed focusing device composed of a Nano-OP30 with objective lens brackets and integrated manual coarse positioning.

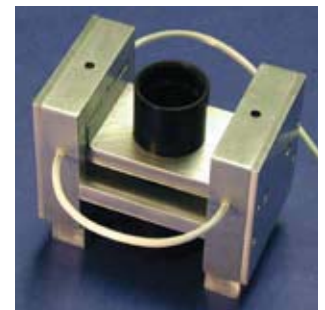

Two Nano-OP25's combined to form an ultra high speed objective lens focusing device.



Nano-OP100 with custom bracket configured to position an objective lens in a high speed optical scanner.

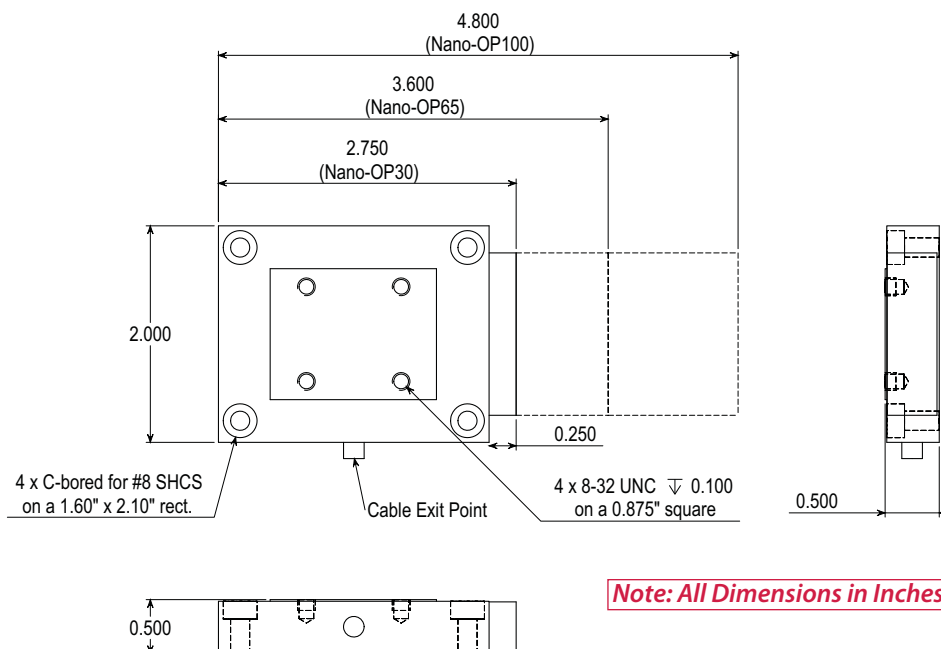

Note: All Dimensions in Inches

פז"מ-טק (1991) בע"מ

מייקל סטורץ' 02.583.2511

PaZaM-tech@pobox.com

www.PaZaM-tech.co.il