

Nano-Align3 Series

Features

- ▶ Low profile: 0.8"
- ▶ Three axis motion (Z , θ_x , θ_y)
- ▶ Large center aperture: 2.6" \times 2.6"
- ▶ Long range: 100 μm or 200 μm (Z), 2mradians or 4mradians (θ_x , θ_y)
- ▶ **pico**™ sensor technology
- ▶ Closed loop control

Typical Applications

- ▶ Z-axis plus tip/tilt alignment
- ▶ Nanolithography
- ▶ Microscopy
- ▶ MEMS

02.583.2511 פז"מ-טק (1991) בע"מ
<Michael.Storch@pazam-tech.co.il>

LabVIEW Compatible USB Interfaces



Examples, tutorial, and
Nano-Route™ 3D supplied
with Nano-Drive™ USB
interfaces.

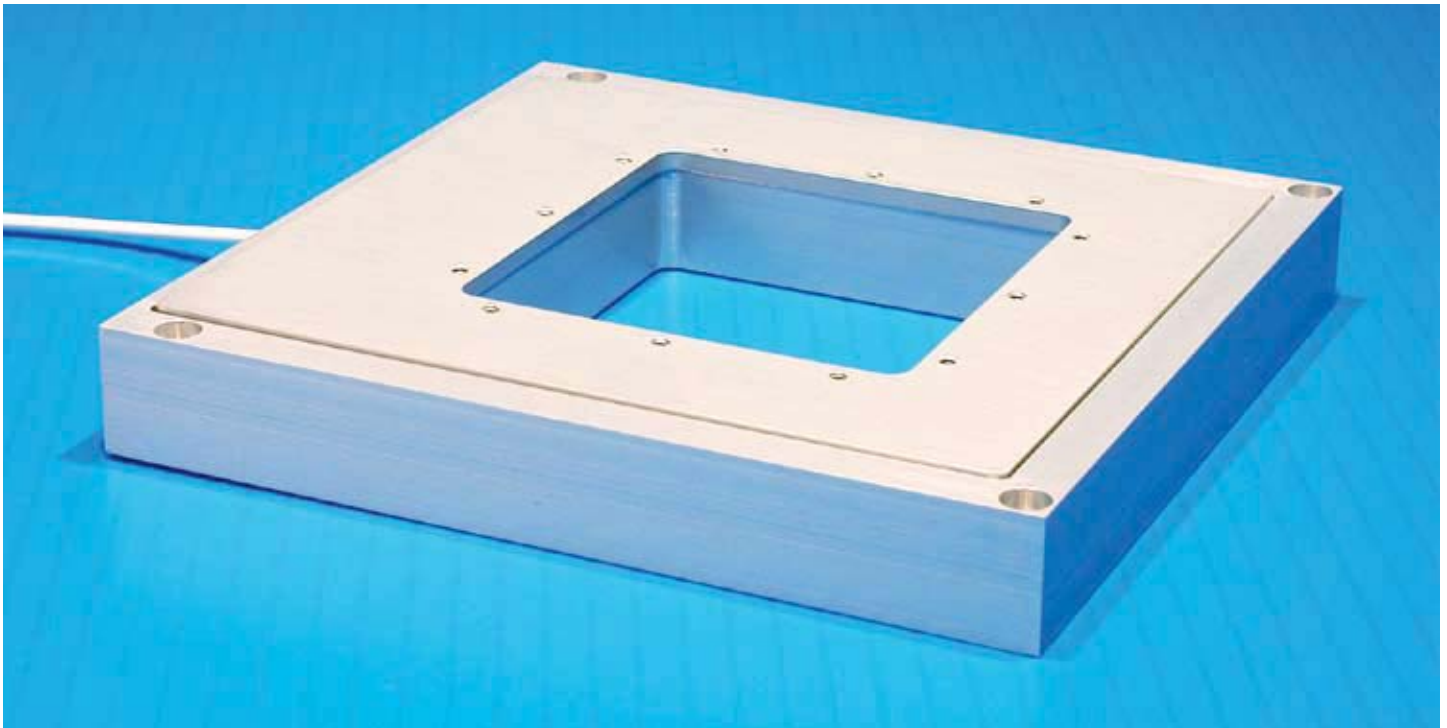

Nano-Align3 constructed from aluminum.

Product Description

The Nano-Align3 is a three axis (Z , θ_x , θ_y) nanopositioning system with a large center aperture. The low profile design of the Nano-Align3 allows it to be integrated into existing instrumentation where space is restricted. The center aperture makes the Nano-Align3 ideal for demanding microscopy alignment applications which require

long range travel and high precision. Internal position sensors utilizing proprietary **pico**™ technology provide picometer and nanoradian precision under closed loop control.

02.583.2511 פז"מ-טק (1991) בע"מ
<Michael.Storch@pazam-tech.co.il>

MCL

phone: 608-298-0855

fax: 608-298-9525

Technical Specifications

Ranges of motion (Nano-Align3-100)

Z axis 100 μm

θ_x and θ_y 2 mradian

Ranges of motion (Nano-Align3-200)

Z axis 200 μm

θ_x and θ_y 4 mradian

Resolution (Nano-Align3-100).....0.2nm/ 4 mradian

Resolution (Nano-Align3-200).....0.4nm/ 8 mradian

Resonant Frequency (Nano-Align3-100) 600 Hz $\pm 20\%$

Resonant Frequency (Nano-Align3-200) 450 Hz $\pm 20\%$

Stiffness 1.0 N/ μm

Recommended max. load (horizontal)* 0.5 kg

Recommended max. load (vertical)* 0.2 kg

Body Material Aluminum, Titanium, or Invar

Controller Nano-Drive™/ Nano-Drive™85

* Larger load requirements should be discussed with our engineering staff.

פד"מ-טק (1991) בע"מ

מייקל סטורץ | 02.583.2511

PaZaM-tech@pobox.com

www.PaZaM-tech.co.il

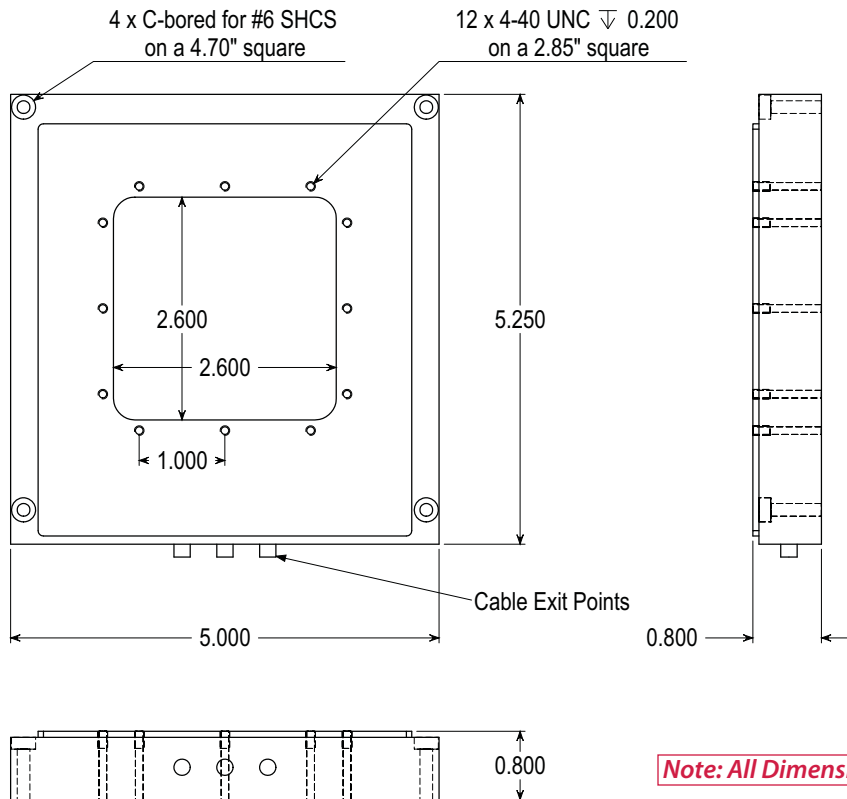

Note: All Dimensions in Inches

פד"מ-טק (1991) בע"מ 02.583.2511
[<Michael.Storch@pazam-tech.co.il>](mailto:Michael.Storch@pazam-tech.co.il)



phone: 608-298-0855

fax: 608-298-9525